

23W Series - Standard Stepper Motors



FEATURES

- **NEMA 23 Frame Size**
- **Best Selection for High Speed Applications**
- **1.8° Step Angle**
- **Torque - Up to 175 oz-in**
- **Can be Customized for**
 - **Winding Current**
 - **Shaft Options**
 - **Cables and Connectors**
- **CE Certified and RoHS Compliant**



DESCRIPTION

The 23W Series Stepper Motors offer a very high value for a standard round style stepper motor. They have lower rotor inertia than square high torque motors which allow them to accelerate faster and offer higher torque at speeds greater than 25 revolutions per second. These motors are an excellent choice to replace many of the round stepper motors that were popular for many years. The motor comes in a standard 8-lead configuration with a broad line of motor windings and stack lengths available off-the-shelf. We can also customize the winding to perfectly match your voltage, current, and maximum operating speed. Special modifications, cables and connectors are also available upon request.

SPECIFICATIONS

Model #	NEMA Size	Bipolar Torque (oz-in)	Unipolar Current (A)	Series RMS Current (A)	Unipolar Inductance (mH)	Rotor Inertia (oz-in-sec ²)	Shaft Diameter (in)	# Lead Wires	Weight (lbs)	"L" Length (in)
23W001S-LW8	23	56	0.4	0.28	30.0	0.00078	0.250	8	1.2	1.6
23W102S-LW8	23	100	1.0	0.7	8.2	0.00156	0.250	8	1.4	2.0
23W104S-LW8	23	100	2.0	1.4	1.8	0.00156	0.250	8	1.4	2.0
23W108S-LW8	23	100	4.0	2.8	0.6	0.00156	0.250	8	1.4	2.0
23W204S-LW8	23	175	2.0	1.4	5.7	0.00283	0.250	8	2.1	3.0
23W209S-LW8	23	175	4.5	3.2	0.8	0.00283	0.250	8	2.1	3.0

Notes: The 7th character "S" denotes a single shaft, use "D" for double shaft. Custom leadwires, cables, connectors, and windings are available upon request.

L010214

DIMENSIONS

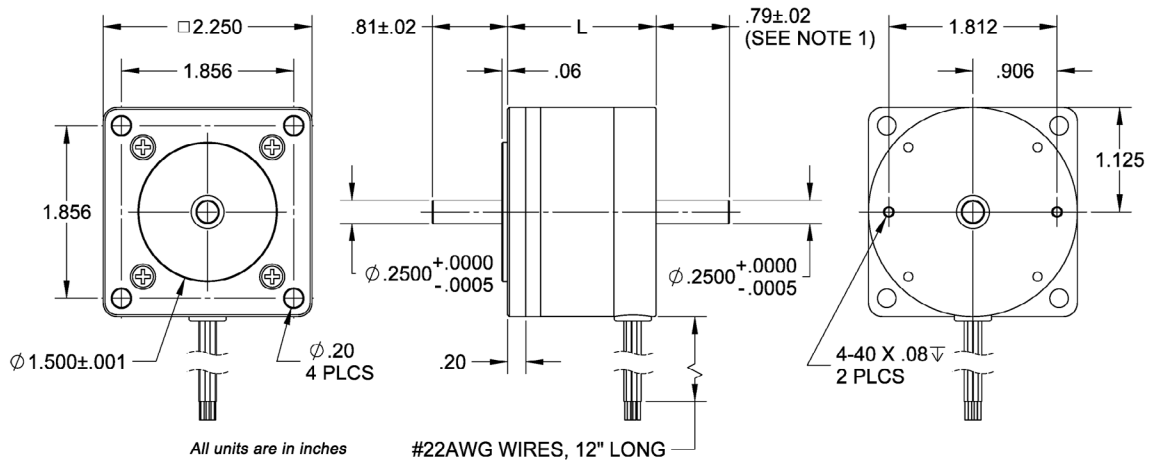

WIRING INFORMATION

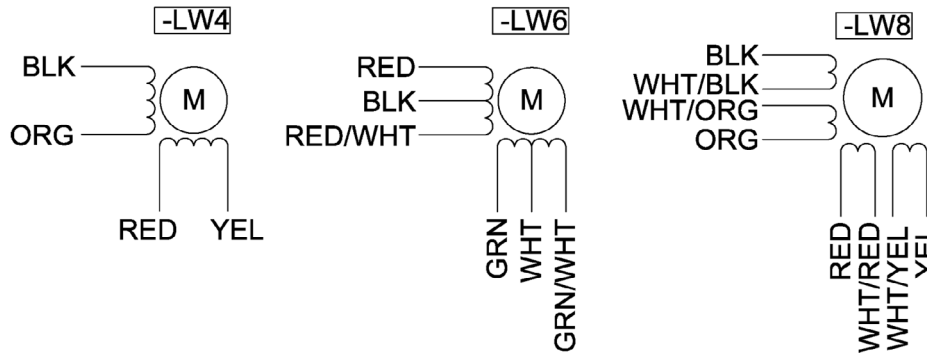

Model #	NEMA Size	Lead Wire Color
4 - Lead Bipolar Series MBC, MLP or MLA Series	Phase 1 (A)	Black
	Phase 3 (/A)	Orange
	Phase 2 (B)	Red
	Phase 4 (/B)	Yellow
	Connect Wires with Wire Nut	White/Black & White/Orange
	Connect Wires with Wire Nut	White/Red & White/Yellow
4 - Lead Bipolar Series MBC or MLP Series	Phase 1	Black & White/Orange
	Phase 3	Orange & White/Black
	Phase 2	Red & White/Yellow
	Phase 4	Yellow & White/Red
6 - Lead Unipolar BLD, TM Series	Phase 1	Black
	Phase 3	Orange
	Phase 2	Red
	Phase 4	Yellow
	Common Phase 1 & 3	White/Black & White/Orange
	Common Phase 2 & 4	White/Red & White/Yellow

SPECIFICATIONS

Step Angle Accuracy:	±5% (full step, no load)	Insulation Resistance:	100M Ohm, Min. 500VDC
Resistance Accuracy:	±10%	Dielectric Strength:	500VAC
Inductance Accuracy:	±20%	Radial Play:	0.02" at 1.0lbs
Temperature Rise:	80°C (2 phase on)	End Play:	0.08" at 1.0lbs
Ambient Temperature:	-20°C - +50°C	Max Radial Force:	16.9lbs (0.79" from flange)
Insulation Type:	Class B	Max Axial Force:	3.37lbs